

# Mini Skip

Mini in name, mighty in action



AMS-600

## Range Features

- These mini skips fit where other skips can not
- Designed to collect waste in confined areas
- Ideally suited for use in production areas: under CNC machines, power presses, drilling machines and many more.
- Castors allow pedestrian operation

## Optional extras

- Oil tight tested
- Oil drain tap
- Colour options
- Special castors

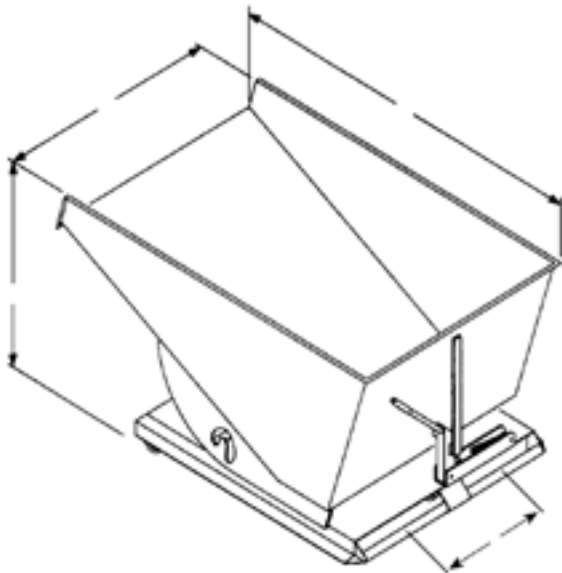

	AMS-450	AMS-600	AMS-750
Capacity (m3)	0.10	0.15	0.19
Capacity (KG)	200	200	200
Unladen weight	37	44	51
<b>Outside dimensions</b>			
Length - L (mm)	840	840	840
Width - W (mm)	450	600	750
Height - H (mm)	480	480	480
<b>Fork tunnels</b>			
Centres - C (mm)	226	346	496
Aperture	150 x 65	180 x 65	180 x 65

### IMPORTANT

The total weight of the skip plus load should not exceed 50% of the fork truck rating. Consideration should be given to the fact that the centre of gravity of the load will move forwards / backwards / sideways when tipping.