

MINERVA 130



The Ágora series litter bins have an elegant design, with balanced forms and different volumes, manufactured in metal or polyethylene and easily adaptable to any urban surroundings: historical centres, gardens and avenues, shopping malls and business parks.

The Ágora series is available with various capacities. The 50-litre Itálica litter bin is easily adaptable to any urban surroundings because of its aesthetics and dimensions. The 80-litre Diana and Atenea are more suitable for larger spaces, such as parks, avenues and shopping malls and, because of its size, the 130-litre Minerva litter bin is suitable for installation in city areas with very large public presence.

Contenur designs and manufactures Agora litter bins to procedures based on ISO 9001, and the Environmental Management System also has ISO 14001 Quality Management certification.

The Contenur Group guarantees the quality of all its products and installations and on request can also offer clients end-to-end product maintenance, including labour and materials. For more information, please contact our Technical Sales network.

Supplied By:

Merlin
Industrial Products Ltd
sales@merlin-industrial.co.uk

Call 0845 124 9955 Fax 0845 125 9955

Litter bins

MINERVA 130

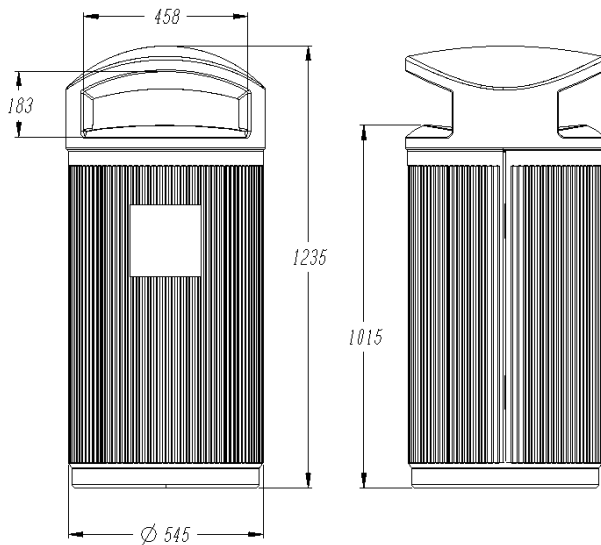

Nominal Capacity	130 litres
Total Height	1235 mm
Basket Capacity	120 litres
Maximum Diameter	545 mm
Total Weight Without Basket	21.80 kg

TECHNICAL FEATURES

Body and access lid manufactured in solid-coloured high-density polyethylene offering colour stability, total corrosion resistance, a smooth finish and the ability to absorb routine impacts without denting or cracking. High density polyethylene is stabilised against both UV radiation and water.

Metal parts are electro-plated or hot-dipped galvanized to eliminate any corrosion points in the finished product.

Filling area comprises two wide openings having 180° access, made up of an upper part that is joined to the body of the bin by two vertical locks giving the whole structure a high degree of mechanical strength.

The 130 litre round body into which the litter is deposited houses the door for emptying. A locking system with a standard triangular key is provided to prevent unauthorised access. Integral cigarette stubber in the body; ashtray can be supplied on request.

120 litre basket is produced in high-density polyethylene and fitted with an integral handle to make emptying easier.

There is the option of replacing the basket with a refuse sack. The system can also be used to segregate two separate materials if a two-compartment basket is fitted.

Vandal-resistant support frame is integrated into the body and fixed to the pavement simply and securely by means of four 12 mm universal expansion bolts.

The latest advances in vandal-resistant technology make the body and lid really robust.

Low maintenance, with the smooth surface preventing accumulation of dirt and facilitating easier cleaning.

They are designed with vertical fluting that reinforces the whole assembly providing originality and elegance. This fluting makes it difficult to stick posters and labels to the body of the bin.

Standard distribution colours: grey and burgundy.

Can be customised on the body, measuring 190 x 190 mm maximum.

Packaged in a cardboard box with the Contenur logo in black, stacked on a pallet 1820 x 1200 x 1900 mm, with a maximum of 9 on each pallet.

The product is supplied fully assembled for ease of transport.